

NOTES:

1. Expansion joints shall be formed by a one-half (1/2) inch thick preformed joint filler, cut to the configuration of the full size of the curb and gutter section and being secured so that they are not moved by depositing and compacting the concrete at these joints. The edges of these joints shall be rounded with an edging tool one-eighth (1/8) inch radius.
2. Expansion joints shall be placed where curb and gutter abuts other structures and at all tangent points to curbs. Expansion joints shall not be spaced more than 50 feet apart on straight runs for hand laid curb and gutter and not more than 100 feet apart for machine laid curb and gutter provided 1/2 inch thick joint filler is used. All joints shall be formed at right angles to the alignment of the curb and gutter.
3. Contraction joints shall be constructed by sawing through the curb and gutter to a depth of not less than one and one-fourth (1 1/4) inches below the surface and to a width not to exceed three-eighths (3/8) inch or they may be formed by inserting a removable metal template in the fresh concrete, or by other methods approved by the engineer. Sealing of joints is not required. Contraction or construction joints shall be located approximately 10 feet apart.
4. Width of curb and gutter may be reduced to 18" at the discretion of the City Engineer for private improvements.

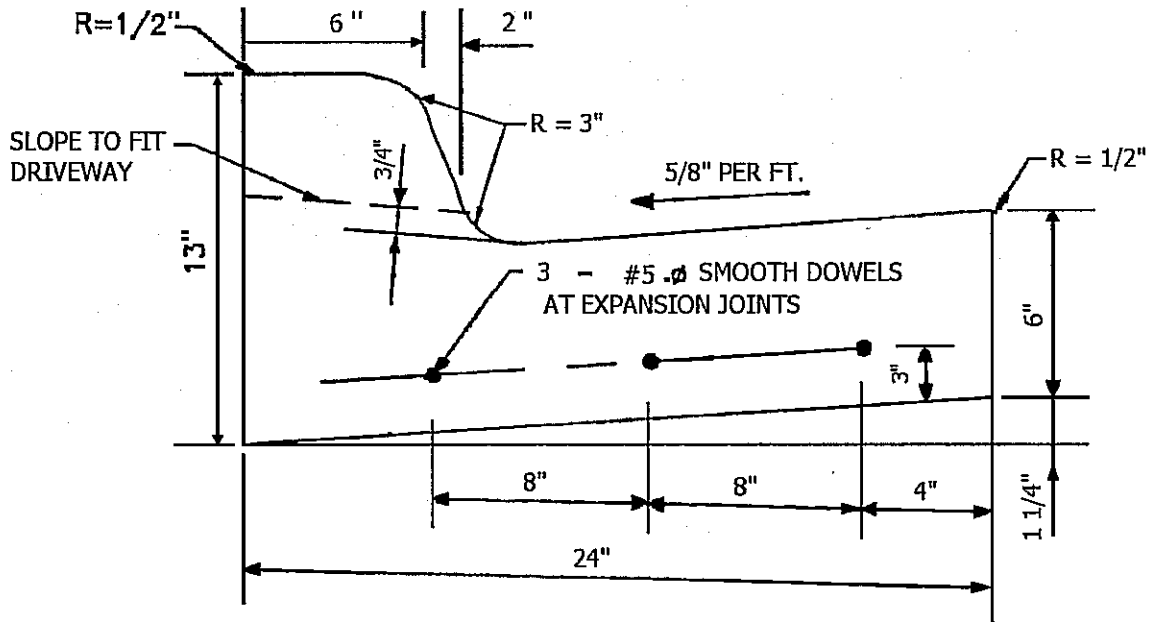

ENGINEERING DEPARTMENT
 COMMERCIAL & MADDUX, BRANSON, MO 65618

**STRAIGHT-BACK
 TYPE "CG-1" CURB
 AND GUTTER DETAIL**

APPROVED

David R. Miller 12/3/07
 CITY ENGINEER DATE

STANDARD DRAWING 21-1